

WHITE LIGHT'S CONSTITUENT COLORS

TOPIC:

Light

SCIENTIST:

Isaac Newton 1642–1727

INTRODUCTION:

The relationship between color and light presented a challenge to early scientists. In 1637, René Descartes (1596–1650) reported that when white light (in this case sunlight) was passed through a prism it somehow separated into the colors of the rainbow. Isaac Newton went a stage further. He determined to prove, once and for all, by his *experimentum crucis* (final demonstration) that white light was a mixture of colored rays although it appeared to be a single entity. Working in a darkened room, he used as his light source a thin beam of sunlight that was shining through a tiny hole in the closed wooden shutter. By placing a glass prism in the light beam he found, like Descartes, that he could project bands of rainbow colors onto a nearby screen. He referred to these colored bands as a “spectrum,” a term we still use today. He continued the experiment by boring a small hole in the screen so that only the red part of the spectrum could shine through onto a second screen placed behind the first. When he placed a second prism in this red beam it did not split up any further. When he repeated the experiment with the other colors he obtained the same result. Newton concluded in 1667 “that light consists of rays differently refrangible”—*i.e.*, white light is made up of component rays which are affected in different ways by a prism. He experimented further and deduced that white light is made up of seven colors, each of which is refracted to a different degree by the prism. Refraction is the change of direction of travel of light rays when they cross the boundary between two media—in this case between air and the glass of the prism. Newton found that when white light passes through a prism some colors are refracted more than others—for example, blue light is refracted more than red light—so that white light splits up into its constituent colors. In the final part of his research, Newton demonstrated that the seven colors of the spectrum can be recombined using a lens and a second prism to produce white light once again.

TIME NEEDED:

1 hour

MATERIALS:

Note: This experiment must be performed in a room that can be darkened.

high-intensity flashlight

masking tape

duct tape

2 pieces of white cardboard 15 cm x 10 cm

piece of black cardboard 15 cm x 10 cm

4 clothespins (to hold the cardboard in place)

X-acto® knife

scissors

cutting board

metric ruler

pencil

black construction paper (if necessary)

2 triangular glass prisms, approximately

7.5 cm long, 2 cm tall, and 2.5 cm wide

Original Materials:

Newton used a beam of sunlight as a source of white light. This was achieved by working in a darkened, south-facing room with bright sunlight outside. A light beam, entering through a small hole in the wooden shutters, was focused using a convex lens. This method can be used today providing conditions are suitable; the flashlight, however, is more convenient.

Safety Precautions

Please read and copy the safety precautions at the beginning of this book. Take care when using the X-acto® knife.

PROCEDURE:

1. Take one of the pieces of white cardboard. Put the flashlight, lens downward, on the cardboard (see figure 1a).
2. Use a pencil to draw the outline of the flashlight lens on the cardboard. Cut out the shape you have just drawn.
3. Put the cardboard shape on the cutting board. Carefully cut a central slit 1–2 mm wide and 5 cm long using the X-acto® knife and the ruler (see figure 1b).
4. Cover the lens of the flashlight with the piece of cardboard with the slit. Use masking tape to hold the cardboard in place, being careful not to cover the slit.
5. Position the flashlight at one end of the table. Make sure that the slit in the cardboard is vertical.
6. Darken the room, using the construction paper taped over the windows if necessary. Switch on the flashlight. Hold the other piece of white cardboard 20 cm away from the flashlight. Make sure that the flashlight projects a narrow, vertical beam of light onto the cardboard. (If not, cut out a new piece of cardboard with a narrower slit.) Now secure the flashlight to the table using duct tape, so that it does not move during the experiment (see figure 1c). Make sure the on/off switch is accessible.

Figure 1

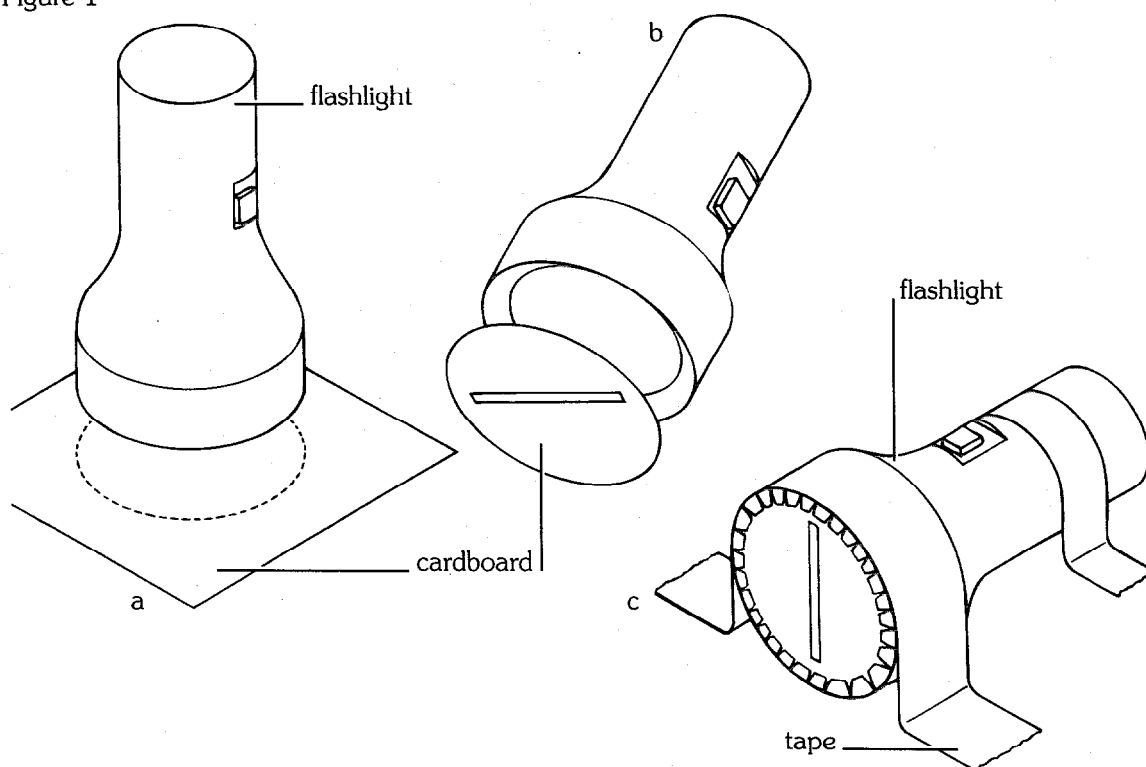

7. Turn on the lights and switch off the flashlight. Take the piece of black cardboard. Measure 7.5 cm from a corner along one of the longer sides, and make a mark with the pencil. Measure 4 cm inward from this point (at right angles to the edge), make a pencil mark, and draw a line between these two points. Cut along the line with the X-acto® knife to make a slit 2 mm wide.

8. Take this piece of cardboard (the barrier) and hold it on the table with the longer side with the slit touching the table. Clip one clothespin to each of the two corners resting on the table so that the cardboard will stand upright on its own.

9. Repeat step 8 with the second piece of white cardboard (the screen), resting either of the two longer sides on the table.
10. Darken the room. Switch on the flashlight.
11. Place the white screen approximately 40 cm away from the flashlight so that you can see the light beam projected onto it.
12. Put the first prism on one triangular face approximately 10 cm from the flashlight.
13. Place the black cardboard barrier in position approximately 15–20 cm away from the flashlight. Record what you see. (If you do not see a spectrum projected onto the barrier, adjust the angle of the prism to the flashlight beam until a spectrum is produced.)
14. Adjust the barrier so that just the red beam can pass through the slit and onto the screen. Record your observations.

Figure 2

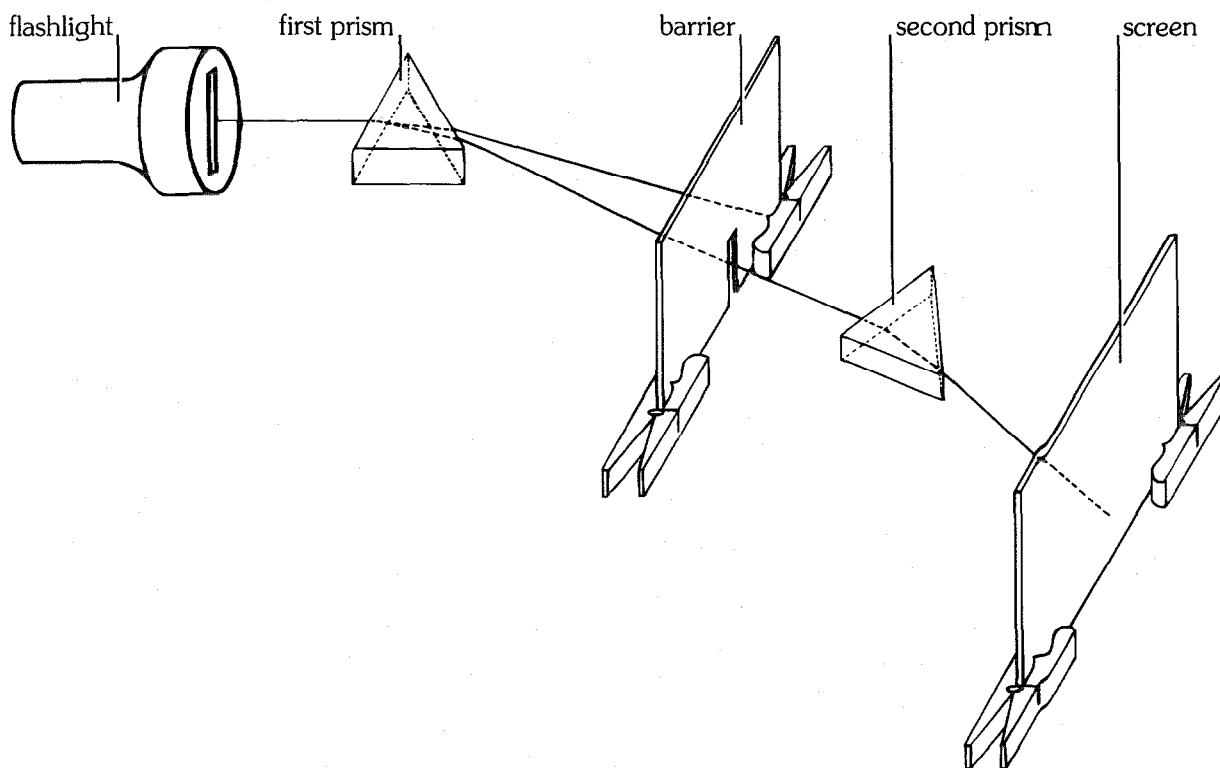

15. Place the second prism in the path of the colored beam between the barrier and the screen, approximately 10 cm from the barrier. Record what happens to the beam and where it hits the screen. (Note: The barrier, screen, and prisms are not necessarily arranged in a straight line. See figure 2.)
16. Repeat steps 14 and 15, adjusting the barrier each time so that the other six colors of the spectrum pass through the slit and onto the screen. Record your results.

ANALYSIS:

1. What did you observe on the barrier when the prism was placed in the beam of white light?
2. What did you observe on the screen when the barrier was adjusted so that it would only allow the red beam to pass through?
3. What happened when the second prism was placed in the path of the red beam? Did these observations vary when different colors were used?
4. What does this experiment tell you about white light?

OUR FINDINGS:

See Section VIII.

SPECIAL SAFETY NOTE TO EXPERIMENTERS

Each experiment includes any special safety precautions that are relevant to that particular project. These do not include all of the basic safety precautions that are necessary whenever you are working on a scientific experiment. For this reason, it is absolutely necessary that you read, copy, and remain mindful of the General Safety Precautions that follow this note.

Experimental science can be dangerous, and good laboratory procedure always includes carefully following basic safety rules. Things can happen very quickly while you are performing an experiment. Things can spill, break, even catch fire. There will be no time after the fact to protect yourself. Always prepare for unexpected dangers by following basic safety guidelines the *entire* time you are performing the experiment, whether or not something seems dangerous to you at a given moment.

We have been quite sparing in prescribing safety precautions for the individual experiments. We made this choice for one reason: We want you to take very seriously every safety precaution that is printed in this book. If you see it written here, you can be sure that it is here because it is absolutely critical to your safety.

One further note: The book assumes that you will read the safety precautions that follow, as well as those in the box within each experiment you are preparing to perform, and that you will *remember* them. Except in rare instances, these precautions will not be repeated in the procedure itself. It is up to you to use your good judgment and pay attention when performing potentially dangerous parts of the procedure. Just because the book does not say **BE CAREFUL WITH HOT LIQUIDS** or **DON'T CUT YOURSELF WITH THE KNIFE** does not mean that you should be careless when simmering water or stripping an electrical wire. It does mean that when you see a special note to be careful, it is extremely important that you pay attention to it.

If you ever have a question about whether a procedure or material is dangerous, wait to perform it until you find out for sure that it is safe.

GENERAL SAFETY PRECAUTIONS

Accidents caused by carelessness, haste, insufficient knowledge, or taking unnecessary risks can be avoided by practicing safety procedures and being alert while conducting experiments. Be sure to check the experiments in this book for additional safety regulations and adult supervision requirements. If you will be working in a lab, do not work alone.

PREPARING:

- Clear all surfaces before beginning experiments
- Read the instructions before you start
- Know the hazards of the experiments and anticipate dangers

PROTECTING YOURSELF:

- Follow the directions step-by-step; do only one experiment at a time
- Locate exits, fire blanket and extinguisher, master gas and electricity shut-offs, eye wash, and first-aid kit
- Make sure there is adequate ventilation
- Do not horseplay
- Wear an apron and goggles
- Do not wear contact lenses, open shoes, loose clothing, or loose hair
- Keep floor and work space neat, clean, and dry
- Clean up spills immediately
- Never eat, drink, or smoke in laboratory or work space
- Do not eat or drink any substances tested unless expressly permitted to do so by a knowledgeable adult

USING EQUIPMENT WITH CARE:

- Set up apparatus far from the edge of the desk
- Use knives and other sharp or pointed instruments with caution
- Pull plugs, not cords, when removing electrical plugs
- Don't use your mouth to pipette; use a suction bulb
- Clean glassware before and after use
- Check glassware for scratches, cracks, and sharp edges
- Clean up broken glassware immediately
- Do not use reflected sunlight to illuminate your microscope
- Do not touch metal conductors
- Use only low voltage and current materials such as lantern batteries
- Be careful when using stepstools, chairs, and ladders

USING CHEMICALS:

- Never taste or inhale chemicals
- Label all bottles and apparatus containing chemicals
- Read labels carefully
- Avoid chemical contact with skin and eyes (wear goggles, apron, and gloves)
- Do not touch chemical solutions
- Wash hands before and after using solutions
- Wipe up spills thoroughly

HEATING SUBSTANCES:

- Use goggles, apron, and gloves when boiling water
- Keep your face away from test tubes and beakers
- Never leave apparatus unattended
- Use safety tongs and heat-resistant mittens
- Turn off hot plates, bunsen burners, and gas when you are done
- Keep flammable substances away from heat
- Have fire extinguisher on hand

FINISHING UP:

- Thoroughly clean your work area and glassware
- Be careful not to return chemicals or contaminated reagents to the wrong containers
- Don't dispose of materials in the sink unless instructed to do so
- Wash your hands
- Clean up all residue and put in proper containers for disposal
- Dispose of all chemicals according to all local, state, and federal laws

BE SAFETY CONSCIOUS AT ALL TIMES